

Company Capability Statement

Introduction

Omni Tanker is an advanced manufacturing company with specialist expertise in carbon fibre polymer matrix composites and thermoplastics. The company's core business is the design, prototyping, certification and manufacture of specialised road tankers, tank containers and high pressure tanks for the safe and efficient transport of liquids and gases, in a range of sizes, for the Australian and International markets.

The tanks produced by Omni Tanker contain advanced thermoplastic corrosion barrier technology with extremely broad chemical resistance for long term use in harsh environments including aggressive corrosive and oxidising chemical service. The use of carbon fibre composites in the tanks results in considerable weight savings which translate to increased payload in transport and aerospace operations.

To support these products, Omni Tanker develops and manufactures lightweight structures in Steel, Aluminium, and Composites. Additionally, Omni Tanker equips its products with highly engineered liquid handling and pipework systems, complete with electrics, that are tailored to specific customer needs. The combination of these advanced tank products, engineered support structures, and integrated liquid handling systems, ensures a smooth user customer experience and results in significant lifetime maintenance savings.

The Company's headquarters and manufacturing facilities are located in Southwest Sydney, Australia. From this facility Omni Tanker services worldwide markets alongside accredited international logistic partners. Omni Tanker is the supplier of choice and technology partner for many of the world's leading Chlor-Alkali chemical producers and associated logistics businesses. Omni Tanker collaborates on projects in composite and structural reinforcement including engineering, product development and manufacturing with the world leading companies in the aerospace, defence and oil & gas sectors.



Process & Machinery

Omni Tanker has a wide range of process and custom engineered machinery capabilities for composite, polymer and metal fabrication. These include:

- Wet Layup
- Filament Winding
- Vacuum Resin Infusion
- Gel Coating & Surface Finishing
- Mould Manufacture
- Polymer Forming and Fabrication
- Environmentally Controlled Manufacture
- Electrical Installation
- Mild & Stainless Steel Fabrication
- Aluminium Fabrication
- 5 Axis Waterjet Cutting
- Equipment Fitment and Assembly
- Tool, Jig and Fixture Manufacture
- Liquid and Gas Handling Fitout
- Polymer and Metallic Pressure Piping
- Capital Equipment Construction



Testing Facilities

Omni Tanker has the following in-house test facilities and test capabilities:

- Convention for Safe Containers (CSC) test rig
- Off-site rail impact test facilities
- Large scale multi-axial static and dynamic testing
- Tank hydrostatic testing to 2200 bar / 31.9 ksi
- Tank cryogenic testing to 150 bar / 2.2 ksi
- Coupon level testing

Quality Assurance

Omni Tanker has a comprehensive quality control programme that focuses on the highest level of engineering standards, production repeatability, regular external and internal audits, and continual improvement.

The organisation has a Quality Management System which is accredited to ISO 9001:2015 (BSI) and a Metallic Welding Quality Management System accredited to ISO 3834-2:2005 (AWI).



Engineering & Product Development

Omni Tanker has an experienced engineering and product development team which includes PhD qualified specialists in composite materials and finite element analysis, as well as a multi-disciplinary array of accreditations which include aerospace engineering, mechatronics, mechanical engineering, electrical engineering and project management.

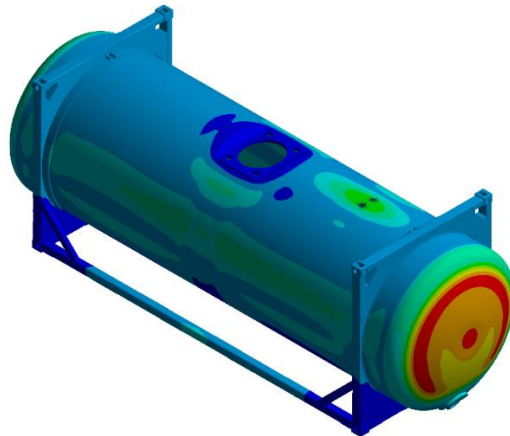

The engineering team is backed up by an expert production team with many years of experience of translating new and revised designs into high performance products. The Company's capability in product development, certification and commercialisation has been recognised with multiple international awards and publications in peer reviewed journals.



International Certifications

Our products are certified to industry standards internationally as listed below.

Jurisdiction	Code and Type of Structure	Certifying Body
Australia	ADG7 for UN Portable Tank Containers for Dangerous Goods Transport AS2809 Road Tanker Vehicles for Dangerous Goods Transport	NSW Environmental Protection Agency
USA	49 CFR 178 for UN Portable Tank Containers and Structural Equipment for Cryogenic Tank Containers 49 CFR 178 for 407/412 Cargo Tank Motor Vehicles	US DOT Pipeline and Hazardous Materials Safety Administration TÜV SÜD Industrie Service
Canada	CSA B625 for Portable Tanks for Transport of Dangerous Goods CSA B620 for Highway Tanks for Transport of Dangerous Goods	Transport Canada
Europe, Asia, Africa	ADR for Road Tankers and Tank Containers for Carriage of Dangerous Goods by Road RID for Tank Containers for Carriage of Dangerous Goods by Rail	German Federal Institute for Materials Research and Testing (BAM) Kiwa Inspecta TÜV SÜD Industrie Service
New Zealand	HSNOCOP39 for Road Tankers for Toxic, Corrosive and Exotoxic Liquids	Worksafe NZ
International Container Transport	Convention for Safe Containers for Container Frames	German Federal Institute for Materials Research and Testing (BAM) Lloyd's Register Silver CIMS
Deep Sea	International Maritime Dangerous Goods (IMDG) Code Chapter 6.7.4 for Structural Equipment for Cryogenic Tank Containers	TÜV SÜD Industrie Service
International Marine Craft	Rules and Regulations for Special Service Craft Section 5 Chapter 14 for Composite Marine Craft Manufacture	Lloyd's Register

Collaborations

Omni Tanker values ongoing collaborations with Australian and International research partners and governing bodies.

The company has a longstanding research partnership with the University of New South Wales (UNSW), and the Australian Research Council Training Centre for Automated Manufacture of Advanced Composites (AMAC).

In 2022, Omni Tanker joined with a number of Australian Universities and other industry partners in establishing The Sovereign Manufacturing Automation for Composites Cooperative Research Centre (SoMAC CRC).

Omni Tanker is a member of the United Nations Sub-Committee of Experts on the Transport of Dangerous Goods Fibre Reinforced Polymer Portable Tank Working Group.

Contact

For more information visit our website: www.omnitanker.com

Contact info@omnitanker.com

Phone: +61 (0) 2 4647 7557